

Manual Instruction

FT 5000lt



CONTENTS

- I. Assignment**
- II. Dimensions**
- III. Equipment**
- IV. Fortis Tank - diagram**
- V. Manual instruction of Panther 72**
 - A. Index
 - B. Machine and Manufacturer Identification
 - C. Declar of Incorporation of partly-completed Machinery
 - D. Machine Description
 - E. Technical Specifications
 - E1. Performance Specifications
 - E2. Electrical Specifications
 - F. Operating Conditions
 - F1. Environmental Conditions
 - F2. Electrical Power Supply
 - F3. Working Cycle
 - F4. Fluids Permitted / Fluids Not Permitted
 - G. Moving and Transport
 - H. Installation
 - H1. Disposing of the Packing MaterialOpis urządzenia
 - H2. Preliminary Inspection
 - H3. Positioning the Pump
 - H4. Connecting the Tubing
 - H5. Considerations Regarding Delivery and Suction Lines
 - H6. Line Accessories
 - H7. Electrical Connections
 - I. Initial Start-Up
 - J. Daily Use
 - K. Problems and Solutions
 - M. Maintenance
 - N. Noise Level
 - O. Disposal
 - P. Exploded Diagrams and Spare Parts
 - R. Dimensions and Weights
- VI. Manual instruction of K33 flow meter**
 - A. Index
 - B. General information
 - C. Installation
 - D. Calibration
 - E. Calibration procedure
 - F. Use
 - G. Use by gravity
 - H. Maintance
 - I. Disassembling reassembling
 - J. Meter unit
 - K. Reset knob
 - L. Measuring chamber
 - M. Gear unit
 - N. Problems, causes and solutions
 - O. Disposal
 - P. Spare Parts

- R. Dimension
- S. Technical Specification

VII. Manual instruction of K600 flow meter

- A. Index
- B. General Information
- C. Daily Use
- D. Calibration (Only Meter Version)
- E. Meter Configuration
- F. Maintenance
- G. Malfunctions
- H. Technical Specifications
- I. Spare Parts

VIII. Overfill prevention device

- A. Mechanical Protection
- B. Electronic Protection

IX. Level and leak detector

- A. Index
- B. Apollo Ultrasonic Oil Level Monitor – General Information
- C. Tools Required
- D. Installation Instructions

I. Assignment

FortisTank has been produced In accordance with the following standards

EN 13341:2005+A1:2011 Thermoplastics static tanks for above ground storage of domestic heating oils, kerosene and diesel fuels – Blow moulded polyethylene, rotationally moulded polyethylene and polyamide 6 by anionic polymerization tanks

II. Dimensions

Product code	Capacity	Meter	Length	Width	Height
FT5000D/k33	5000l	mechanical K33	2,95 m	2,38 m	2,03 m

III. Equipment

FORTIS TANK 5000l with mechanical fuel flow meter K 33

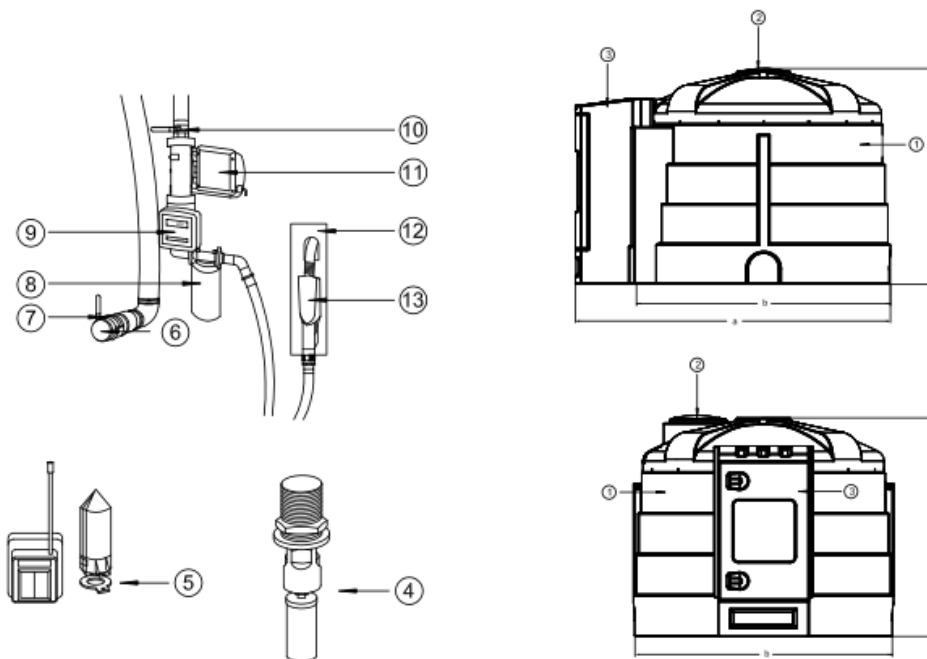

Capacity [l]	Dimension [mm]			Weight [kg]
	a	b	c	
5000	2950	2380	2030	400

1	Outertank
2	Inspection manhole
3	Distribution box
4	Overfill prevention device
5	Wireless fuel level sensor connected with inter-shell space monitoring system
6	Quick-joint for cisterns 2"
7	Valve
8	Fuel cleaning filter
9	Mechanical meter K 33
10	Valve 1"
11	Pump 230V, 72 l/min
12	Nozzle holder
13	Nozzle

Tank	
Material type	polyethylene
Discription of the product to be stored	diesel fuels, GNR
Distributing system 230V	
Flow rate	72 l/min
Outflow hose 6m with authomatic nozzle	

IV. Fortis Tank - diagram

OUTERTANK WITH DISTRIBUTION BOX

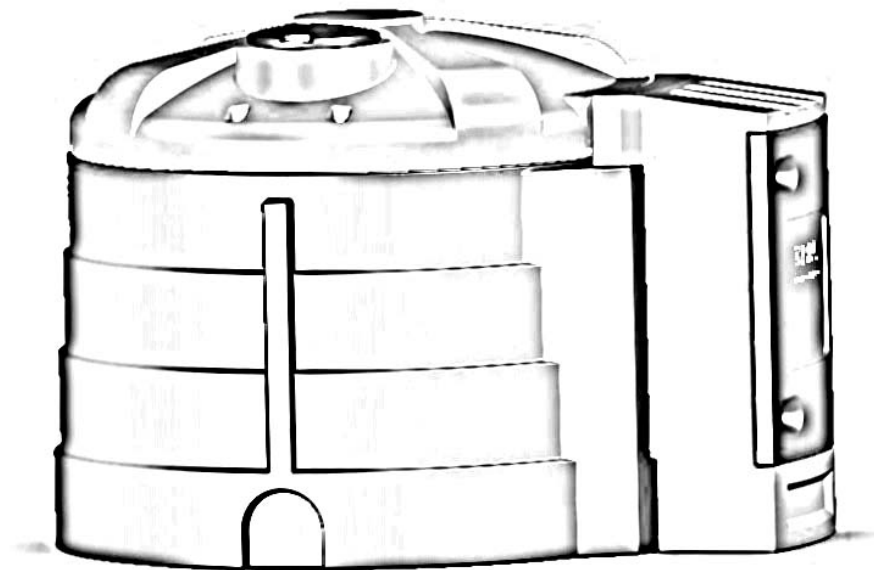

INNERTANK



V. Manual instruction of the pump Panther 56 – 72



A. Index

- A. Index
- B. Machine and Manufacturer Identification
- C. Declar of Incorporation of partly-completed Machinery
- D. Machine Description

- E. Technical Specifications
 - E1. Performance Specifications
 - E2. Electrical Specifications
- F. Operating Conditions
 - F1. Environmental Conditions
 - F2. Electrical Power Supply
 - F3. Working Cycle
 - F4. Fluids Permitted / Fluids Not Permitted
- G. Moving and Transport
- H. Installation
 - H1. Disposing of the Packing Material Opis urządzenia
 - H2. Preliminary Inspection
 - H3. Positioning the Pump
 - H4. Connecting the Tubing
 - H5. Considerations Regarding Delivery and Suction Lines
 - H6. Line Accessories
 - H7. Electrical Connections
- I. Initial Start-Up
- J. Daily Use
- K. Problems and Solutions
- L. Maintenance
- M. Noise Level
- N. Disposal
- O. Exploded Diagrams and Spare Parts
- P. Dimensions and Weights

B. Machine and Manufacturer Identification

Available Models:

- * **PANTHER 56** 230V/50HZ
- * **PANTHER 56** 230V/60HZ
- * **PANTHER 72** 230V/50HZ

MANUFACTURER: **PIUSI SPA**

VIA PACINOTTI – Z.I. RANGAVINO

46029 SUZZARA (MN)

IDENTIFICATION PLATE (EXEMPLE WITH THE FIELDS IDENTIFIED):



C. Declar of Incorporation of partly-completed Machinery

The undersigned: **PIUSI S.p.A - Via Pacinotti c.m. - z.i.Rangavino
46029 Suzzara (Mantova) - Italy**

HEREBY STATES under its own responsibility, that the partly-completed machinery:

Description: **Machine designed for the transfer of diesel fuel**

Model: **Panther 56 / Panther 72**

Serial number: **refer to Lot Number shown on CE plate affixed to product**

Year of manufacture: **refer to the year of production shown on the CE plate affixed to the product**

is intended to be incorporated in a machine (or to be with other machines) so as to create a machine to which applies Machine Directive 2006/42/EC, may not be brought into service before the machine into which it is to be incorporated has been declared in conformity with the provisions of the directive 2006/42/EC.

is in conformity with the legal provisions indicated in the directives:

- **Machine Directive 2006/42/EC**

- **Low-Voltage Directive 2006/95/EC**

- **Electromagnetic Compatibility Directive 2004/108/EC**

D. Machine Description

PUMP: Self-Priming, volumetric, rotating electric vane pump, equipped with by-pass valve.

MOTOR: Asynchronous motor, single-phase and three-phase, 2 pole, closed type (protection class IP55 in conformance with EN 60034-5-86 regulations) self-ventilated, directly flanged to the pump body.

FILTER: Inspectable suction filter

E. Technical Specifications

E1. Performance Specifications

The performance diagram shows flow rate as a function of back pressure.

Functioning Point	Model	Flow Rate	Back Pressure	Typical Delivery Configuration					
				4 meters of 3/4" tube	4 meters of 1" tube	K33/K44 Meter	Self 2000 Manual Dispensing Nozzle	PA60 Automatic Dispensing Nozzle	PA80 Automatic Dispensing Nozzle
A (Maximum Flow Rate)	Panther 56	60	0,5	•			•		
	Panther 72	80	0,5		•		•		
	Panther 56 60 Hz	75	0,5		•		•		

	Panther 56 100/110-50 Hz	45	0,5	.			.		
	Panther 56 100/110-60 Hz	54	0,5	.			.		
B (Maximum Back Rate)	Panther 56	56	1,5	.		.		.	
	Panther 72	72	1,3		.	.			.
	Panther 56 60 Hz	98	1,4		.	.			.
	Panther 56 100/110-50 Hz	42	1,4	.		.		.	
	Panther 56 100/110-60 Hz	50	1,4	.		.		.	
C (Bypass)	Panther 56	0	2,7	Delivery Closed					
	Panther 72	0	2,8						
	Panther 56 60 Hz	0	2,8						
	Panther 56 100/110-50 Hz	0	2,7						
	Panther 56 100/110-60 Hz	0	2,8						

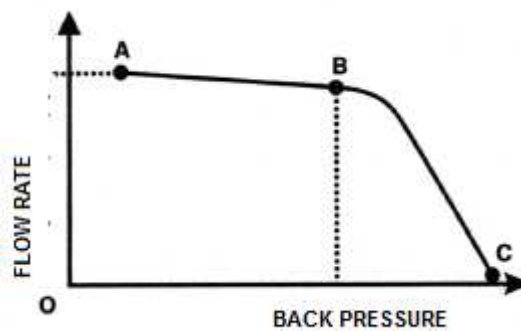

ATTENTION

The curve reverts to the following operating conditions:

Fluid: Diesel Fuel

Temperature: 20°C

Suction Conditions: The tube and the pump position relative to the fluid level is such that a pressure of 0.3 bar is generated at the nominal flow rate.

Under different suction conditions higher pressure values can be created that reduce the flow rate compared to the same back pressure values.

To obtain the best performance, it is very important to reduce loss of suction pressure as much as possible by following these instructions:

- Shorten the suction tube as much as possible
- Avoid useless elbows or throttling in the tubes

- Keep the suction filter clean
 - Use a tube with a diameter equal to, or greater than, indicated (see Installation)
- The burst pressure of the pump is of 20 bar.

E2. Electrical Specifications

MODEL PUMP	ELECTRICAL POWER			POWER	CURRENT
	CURRENT	VOLTAGE [V]	FREQUENCY [Hz]	NOMINAL (*) [Watt]	MAXIMUM (*) [Amp]
PANTHER 56 230V/50Hz	AC	230	50	370	2,2
PANTHER 56 230V/60Hz	AC	230	60	370	2,2
PANTHER 72 230V/50Hz	AC	230	50	550	3,3
PANTHER 56 400V/50Hz	AC	400	50	370	0,9
PANTHER 56 400V/60Hz	AC	400	60	370	0,9
PANTHER 72 400V/50Hz	AC	400	50	550	1,3
PANTHER 56 110V/50Hz	AC	110	50	500	5,5
PANTHER 56 110V/60Hz	AC	110	60	700	7,5
PANTHER 56 100V/50Hz	AC	100	50	550	6,5
PANTHER 56 100V/60Hz	AC	100	60	600	7,8

(*) refers to functioning with maximum back pressure

F. Operating Conditions

F1. Environmental Conditions

TEMPERATURE: **RELATIVE HUMIDITY:**
 Min. -20°C / maks. +60°C maks. 90%

ATTENTION

The temperature limits shown apply to the pump components and must be respected to avoid possible damage or malfunction.

F2. Electrical Power Supply

Depending on the model, the pump must be supplied by a single-phase alternating current line whose nominal values are shown in the table in Paragraph E2 - ELECTRICAL SPECIFICATIONS.

The maximum acceptable variations from the electrical parameters are:

Voltage: +/- 5% of the nominal value
Frequency: +/- 2% of the nominal value

ATTENTION

Power from lines with values outside the indicated limits can damage the electrical components.

F3. Working Cycle

The pumps are designed for continuous use under conditions of maximum back pressure.

ATTENTION

Functioning under by-pass conditions is only allowed for brief periods of time (2-3 minutes maximum).

F4. Fluids Permitted/Fluids Not Permitted

PERMITTED:

– DIESEL FUEL at a viscosity of from 2 to 5,35 cSt (at a temperature of 37,8oC).
Minimum Flash Point (PM) 55oC

NOT PERMITTED:

- GAZOLINE,
- INFLAMMABLE LIQUIDS with PM < 55oC,
- LIQUIDS WITH VISCOSITY > 20 cSt,
- WATER,
- FOOD LIQUIDS,
- CORROSIVE CHEMICAL PRODUCTS,
- SOLVENTS.

RELATED DANGERS:

- FIRE - EXPLOSION,
- MOTOR OVERLOAD,
- PUMP OXIDATION,
- CONTAMINATION OF THE SAME,
- PUMP CORROSION,
- INJURY TO PERSONS,
- FIRE - EXPLOSION,
- DAMAGE TO GASKET SEALS.

G. Moving and Transport

Given the limited weight and size of the pumps (see overall dimensions), ***moving the pumps does not require the use of lifting devices.***

The pumps were carefully packed before shipment.

Check the packing material on delivery and store in a dry place.

H. Installation

H1. Disposing of the Packing Material

The packing material does not require special precautions for its disposal, not being in any way dangerous or polluting.

Refer to local regulations for its disposal.

H2. Preliminary Inspection

- Check that the machine has not suffered any damage during transport or storage.
- Clean the inlet and outlet openings, removing any dust or residual packing.
- Make sure that the motor shaft turns freely.
- Check that the electrical specifications correspond to those shown on the identification plate.

H3. Positioning the pump

- The pump can be installed in any position (pump axis vertical or horizontal)
- Attach the pump using screws of adequate diameter for the attachment holes provided in the base of the pump (see the section "OVERALL DIMENSIONS" for their position and dimension).

ATTENTION

THE MOTORS ARE NOT OF AN ANTI-EXPLOSIVE TYPE.

Do not install them where inflammable vapors can be present.

H4. Connecting the Tubing

- Before connection, make sure that the tubing and the suction tank are free of dirt and thread residue that could damage the pump and its accessories.
- Before connecting the delivery tube, partially fill the pump body with diesel fuel to facilitate priming.
- Do not use conical threaded joints that could damage the threaded pump openings if excessively tightened.

SUCTION TUBING:

- Minimum recommended nominal diameter: 1-1/4"
- Nominal recommended pressure: 10 bar
- Use tubing suitable for functioning under suction pressure

DELIVERY TUBING:

- Minimum recommended nominal diameter: 1"
- Nominal recommended pressure: 10 bar

ATTENTION

It is the installer's responsibility to use tubing with adequate characteristics.

The use of tubing unsuitable for use with Diesel fuel can damage the pump, injure persons and cause pollution.

Loosening of the connections (threaded connections, flanging, gasket seals) can cause serious ecological and safety problems.

Check all the connections after the initial installation and on a daily basis after that.

Tighten the connections, if necessary.

H5. Considerations Regarding Delivery and Suction Lines

DELIVERY

The choice of pump model must be made keeping the **characteristics of the system in mind**.

The combination of the length of the tubing, the diameter of the tubing, the flow rate of the diesel fuel and the line accessories installed can create back pressure **greater than the maximums anticipated** such as to cause the (partial) opening of the pump by-pass with the consequent noticeable reduction of the flow rate supplied.

In such cases, to allow correct functioning of the pump, **it is necessary to reduce system resistance**, using shorter tubing and/or of wider diameter and line accessories with less resistance (e.g. , an automatic dispensing nozzle for greater flow rates).

SUCTION

Panther 56 and Panther 72 pumps are self-priming and characterized by good suction capacity.

During the start-up phase, with an empty suction tube and the pump wetted with fluid, the electric pump unit is capable of suctioning the liquid with a maximum difference in height of 2 meters. It is important to point out that the priming time can be as long as one minute and the presence of an automatic dispensing nozzle on the delivery line prevents the evacuation of air from the installation, and, therefore, prevents proper priming.

For this reason, it is always advisable to prime the pump without an automatic delivery nozzle, verifying the proper wetting of the pump. The installation of a foot valve is recommended to prevent the emptying of the suction tube and keep the pump wet. In this way, the pump will subsequently always start up immediately.

When the system is functioning, the pump can work with pressure at the inlet as high as 0.5 bar, beyond which cavitation phenomena can begin, with a consequent loss of flow rate and increase of system noise.

As we have said up to this point, it is important to guarantee low suction pressure by using short tubing of a diameter equal to or larger than recommended, reducing curves to a minimum and using suction filters of wide cross-section and foot valves with the lowest possible resistance.

It is very important to keep the suction filters clean because, once clogged, they increase

system resistance.

The difference in height between the pump and the fluid level must be kept as small as possible and, at any rate, within the 2 meters anticipated for the priming phase. If this height is exceeded, it will always be necessary to install a foot valve to allow for the filling of the suction tube and provide tubing of wider diameter. It is recommended that the pump not be installed at a difference in height greater than 3 meters.

ATTENTION

In the case that the suction tank is higher than the pump, it is advisable to install an antisiphon valve to prevent accidental diesel fuel leaks. Dimension the installation in order to control the back pressures due to water hammering.

H6. Line Accessories

The pumps are furnished without line accessories. Following is a list of the most common line accessories whose use is compatible with the proper functioning of the pumps.

DELIVERY

Automatic dispensing nozzle

Manual dispensing nozzle

Meter

Flexible tubing

SUCTION

Foot valve with filter

Rigid and flexible tubing

ATTENTION

It is the installer's responsibility to provide the line accessories necessary for the safe and proper functioning of the pump.

The use of accessories unsuitable for use with diesel fuel can damage the pump, injure persons and cause pollution.

H7. Electrical Connections

SINGLE-PHASE MOTORS

Single-phase motors are supplied with a pre-existing 2-meter cable with electric plug. To change the cable, open the terminal strip cover and connect the line according to the following diagram:

SINGLE PHASE

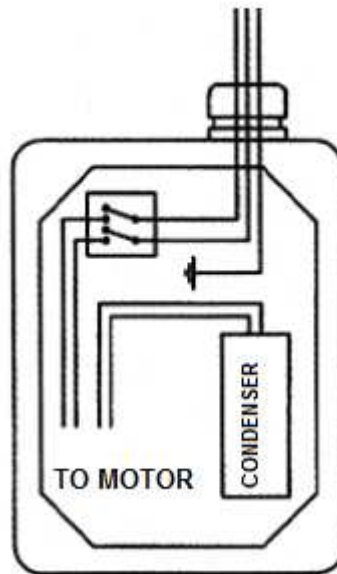

THREE PHASE A.C. LINE

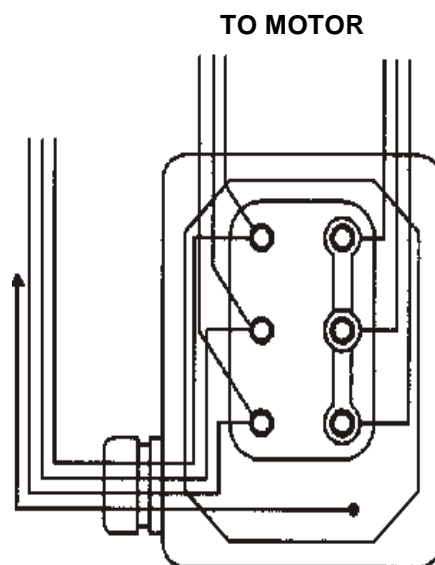

Single-phase motors are supplied with a bipolar switch and capacitor wired and installed inside the terminal strip box (see diagram).

The characteristics of the capacitor are shown on the identification plate for each pump model. The switch has the sole function of starting / stopping the pump and cannot in any way substitute for the main circuit breaker provided for in the applicable regulations.

THREE-PHASE MOTORS

Three-phase motors are supplied with a terminal strip box and terminal strip.

To connect the electric motor to the electric power line, open the terminal strip cover and connect the cables according to the diagram.

ATTENTION

Verify that the terminal strip blades are positioned according to the diagram provided for the available power supply voltage. Verify the correct direction of rotation of the motor

(see the paragraph overall dimensions), and, if not correct, invert the connection of the two cables in the power supply plug or on the terminal strip.

The pumps are supplied without electrical safety equipment such as fuses, motor protectors, systems to prevent accidental restarting after power failures or others. It is indispensable to install an electric panel, upstream from the pump's power supply line, equipped with an appropriate residual current operated circuit breaker.

It is the installer's responsibility to perform the electrical connections with respect for the applicable regulations.

Respect the following (**not exhaustive**) instructions to ensure a proper electrical installation:

- During installation and maintenance, make sure that the electric supply lines are not live.
- Use cables characterized by the minimum cross-sections, nominal voltages and wiring-type adequate to the characteristics shown in Paragraph E2 ELECTRICAL SPECIFICATIONS and the installation environment.
- In three-phase motors verify the correct direction of rotation (see Paragraph R - DIMENSIONS AND WEIGHTS)
- All motors are equipped with a ground terminal to connect to the ground line of the electrical network.
- Always close the cover of the terminal strip box before supplying electrical power, after ascertaining the integrity of the gasket seals that ensure protection grade IP 55.

I. Initial Start-Up

- Check that the quantity of diesel fuel in the suction tank is greater than the amount you wish to transfer.
- Make sure that the residual capacity of the delivery tank is greater than the quantity you wish to transfer.
- Do not run the pump dry. This can cause serious damage to its components.
- Make sure that the tubing and line accessories are in good condition. Diesel fuel leaks can damage objects and injure persons.
- Never start or stop the pump by inserting or removing any plugs.
- Do not operate switches with wet hands.
- Prolonged contact with diesel fuel can damage the skin. The use of glasses and gloves is recommended.
- Single phase motors are provided with an automatic thermal protection switch.

ATTENTION

Extreme operating conditions can raise the motor temperature and, consequently, cause the thermal protection switch to stop it.

Turn off the pump and wait for it to cool before resuming use.

The thermal protection automatically turns off when the motor is sufficiently cool.

In the priming phase the pump must blow the air initially present in the entire installation out of the delivery line. Therefore it is necessary to keep the outlet open to permit the evacuation of the air.

ATTENTION

If an automatic type dispensing nozzle is installed on the end of the delivery line, the evacuation of the air will be difficult because of the automatic stopping device that keeps the valve closed when the line pressure is too low. It is recommended that the automatic dispensing nozzle be temporarily disconnected during the initial start-up phase.

The priming phase can last from several seconds to a few minutes, as a function of the characteristics of the system. If this phase is prolonged, stop the pump and verify:

- That the pump is not running completely dry;
- That the suction tubing is not allowing air to seep in;

- That the suction filter is not clogged;
- That the suction height is not greater than 2 meters (if the height is greater than 2 meters, fill the suction tube with fluid);
- That the delivery tube is allowing the evacuation of the air.

When priming has occurred, verify that the pump is operating within the anticipated range, in particular:

- That under conditions of maximum back pressure, the power absorption of the motor stays within the values shown on the identification plate;
- That the suction pressure is not greater than 0.5 bar;
- That the back pressure in the delivery line is not greater than the maximum back pressure anticipated for the pump.

J. Daily Use

- If using flexible tubing, attach the ends of the tubing to the tanks. In the absence of an appropriate slot, solidly grasp the delivery tube before beginning dispensing.
- Before starting the pump make sure that the delivery valve is closed (dispensing nozzle or line valve).
- Turn the ON/OFF switch to ON. The bypass valve allows functioning with the delivery closed for only brief periods.
- Open the delivery valve, solidly grasping the end of the tubing.
- Close the delivery valve to stop dispensing.
- When dispensing is finished, turn off the pump.

ATTENTION

Functioning with the delivery closed is only allowed for brief periods (2-3 minutes maximum). After use, make sure the pump is turned off.

LACK OF ELECTRIC POWER:

A lack of electric power, with the consequent accidental stopping of the pump, can be caused by:

- A safety device tripping
- A drop in line voltage

In either case, act as follows:

- Close the delivery valve
- Attach the end of the delivery to the slot provided on the tank
- Turn the ON/OFF switch to the OFF position.

Resume operations as described in Paragraph L - DAILY USE, after determining the cause of the stoppage.

K. Problems and Solutions

Problem	Possible Cause	Solution
THE MOTOR IS NOT TURNING	Lack of electric power	Check the electrical connections and the safety systems
	Rotor jammed	Check for possible damage or obstruction of the rotating components
	The motor protecting thermal switch has tripped	Wait for the motor to cool, verify that it restarts, and research the cause of the overheating
	Motor problems	Contact the service Department
THE MOTOR TURNS SLOWLY	Low voltage in the electric power line	Bring the voltage back within the anticipated limits

WHEN STARTING		
LOW OR NO FLOW RATE	Low level in the suction tank	Refill the tank
	Foot valve blocked	Clean and/or replace the valve
	Filter clogged	Clean the filter
	Excessive suction pressure	Lower the pump with respect to the level of the tank or increase the cross-section of the tubing
	High loss of head in the circuit (working with the by-pass open)	Use shorter tubing or of greater diameter
	By-pass valve blocked	Dismantle the valve, clean and/or replace it
	Air entering the pump or the suction tubing	Check the seals of the connections
	A narrowing in the suction tubing	Use tubing suitable for working under suction pressure
	Low rotation speed	Check in the voltage at the pump. Adjust the voltage and/or use cables of greater cross-section
INCREASED PUMP NOISE	The suction tubing is resting on the bottom of the tank	Raise the tubing
	Cavitation occurring	Reduce suction pressure
	Irregular functioning of the by-pass	Dispense until the air is purged from the circuit
LEAKAGE FROM THE PUMP BODY	Air present in the diesel fuel	Verify the suction connections
	Seal damaged	Check and replace the mechanical seal

L. Maintenance

Panther 56 and Panther 72 pumps are designed and constructed to require a minimum of maintenance.

- On a weekly basis, check that the tubing joints have not loosened, to avoid any leakage.
- On a monthly basis, check the pump body and keep it clean of any impurities.
- On a monthly basis, check and keep the pump filter clean and any other filters installed.
- On a monthly basis, check that the electric power supply cables are in good condition.

M. Noise Level

Under normal working conditions the noise emission from all models does not exceed the value of **70 db at a distance of 1 meter** from the electric pump.

N. Disposal

The components must be given to companies that specialise in the disposal and recycling of industrial waste and, in particular, the:

DISPOSAL OF PACKAGING:

The packaging consists of biodegradable cardboard which can be delivered to companies for normal recycling of cellulose.

DISPOSAL OF METAL COMPONENTS:

The metal components, both painted and stainless steel, are usually recycled by companies that are specialised in the metal-scraping industry.

DISPOSAL OF ELECTRIC AND ELECTRONIC COMPONENTS:

these have to be disposed by companies that are specialised in the disposal of electronic components, in accordance with the instructions of 2002/96/EC (see text of Directive below).

ENVIRONMENTAL INFORMATION FOR CUSTOMERS IN THE EUROPEAN UNION:

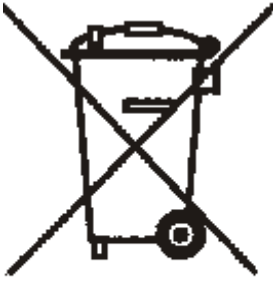

European Directive 2002/96/EC requires that the equipment bearing this symbol on the product and/or its packaging must not be disposed of with unsorted municipal waste. The symbol indicates that this product should be disposed of separately from regular household waste streams.

It is your responsibility to dispose of this and other electric and electronic equipment via designated collection facilities appointed by the government or local authorities.

DISPOSAL OF OTHER PARTS:

The disposal of other parts such as pipes, rubber seals, plastic components and cables should be

entrusted to companies that special in the disposal of industrial waste.

wyrzucać zanieczyszczonych części do środowiska naturalnego.
Prawidłowe ich usuwanie określają lokalne przepisy.

O. Exploded Diagrams and Spare Parts

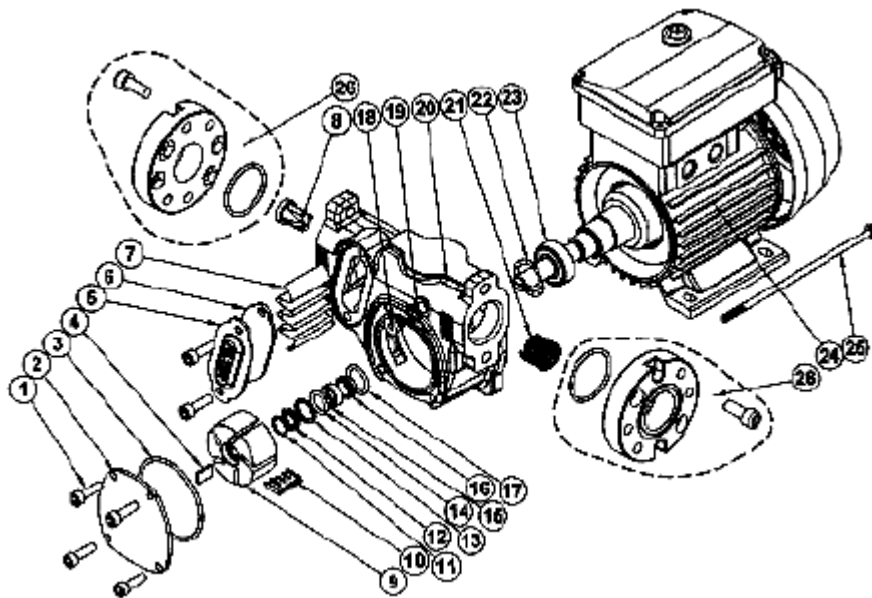

P. Dimensions [mm] and Weights

PANTHER 56: 7,0 kg

PANTHER 72: 8,2 kg

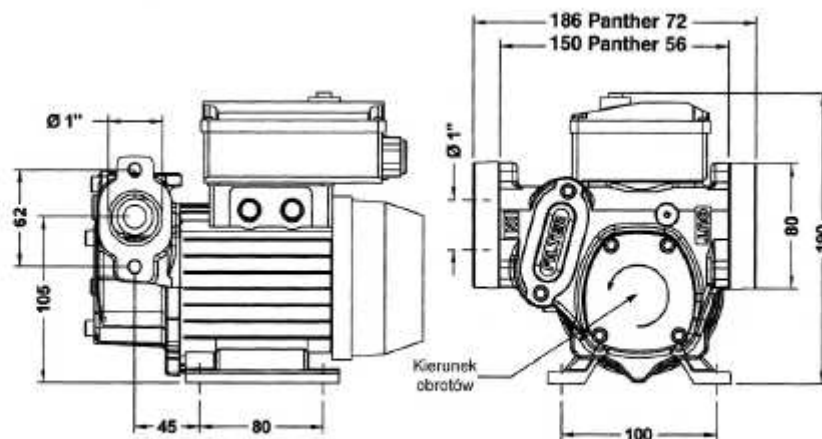

VI. Manual instruction of K33 flow meter



A. Index

- A. Index
- B. General information
- C. Installation
- D. Calibration
- E. Calibration procedure
- F. Use
- G. Use by gravity
- H. Maintenance
- I. Disassembling reassembling
- J. Meter unit
- K. Reset knob
- L. Measuring chamber
- M. Gear unit
- N. Problems, causes and solutions
- O. Disposal
- P. Spare Parts
- R. Dimension
- S. Technical Specification

B. General Information

K33 is a mechanical flowmeter with nutating disk, designed to allow a precise measurement of Diesel oil or other fluids compatible with the manufacturing material. The nutating disk of the metering chamber (seediagram 1, drawing "15"), which is set in motion by the fluid itself, drives the gear train located in the cover of the meter body (drawing "8") which transmits the motion to the meter (pos. "6"). The meter is equipped with a non-resettable litre totaliser and a batch register which can be reset by means of a knob (Pos. "2") whose unit digit is provided with marks for the readout of the tenths of a litre.

ATTENTION

To ensure a proper and safe use of the meter it is necessary to read and follow the instructions and warnings contained in this manual. An improper installation or use of the meter may cause damage to objects and people.

Technical Data		Model K33		
Meter mechanism		Nutating disk		
Flow rate	(range)	20 ÷ 120 litres/min		
Operating pressure	(max)	3,5 bar		
Burst pressure	(min)	28 bar		
Storage temperature	(range)	-20 ÷ +80 °C		
Storage humidity	(max)	95% RU		
Operating temperature	(range)	- 10 ÷ +60		
Pressuer loss with diesel oil	Flow rate [l/min]	30	60	90
	Pressuer loss [bar]	0,005	0,2	0,4
Accuracy after calibration		+/- 1%		
Repeatability	(typical)	+/- 0,3%		
Batch total readout		3 digits high 18mm		

Totaliser readout		6 digits high 6mm
Readout resolution		0,1 l
Connections	(inlet/outlet)	1*BSP
Weight	(approximate)	1,8 kg
Package dimensions		185x185x170 mm
Optional features		Registration in US gallons female threaded inlet/outlet 1"NPT

C. Installation

The meter K33 can be installed in any position, on rigid pipelines or flexible hoses, directly on pumps or tanks. The meter flow direction is fixed and indicated by an arrow. The meter is supplied in the standard configuration (A). The meter and the cover (see diagram1, pos. "3") can be rotated by 90° to 90° in respect to the body in order to carry out the different configurations shown (B, C, D). The reset knob can be installed either on the right side or on the left side of the meter. In order to modify the standard configuration follow the instructions given in section "Disassembling / Re-assembling". The meter body is equipped with 4 blind holes (see diagram 2) which can be threaded (M5) for a possible fastening. If solid particles enter the measuring chamber the correct working of the nutating disk may be affected. Always filter the fluid by installing a filter on the meter inlet (recommended filter 400 µ).

D. Calibration

K33 IS pre-calibrated in factory to be used with Diesel oil. As specific operating conditions (such as real flow rate, nature and temperature of the measured fluid) may affect the meter accuracy, a re-calibration should be carried out after the installation has been completed.

A new calibration is necessary each time the meter is disassembled for maintenance operations or when it is used to measure fluids that differ from Diesel oil.

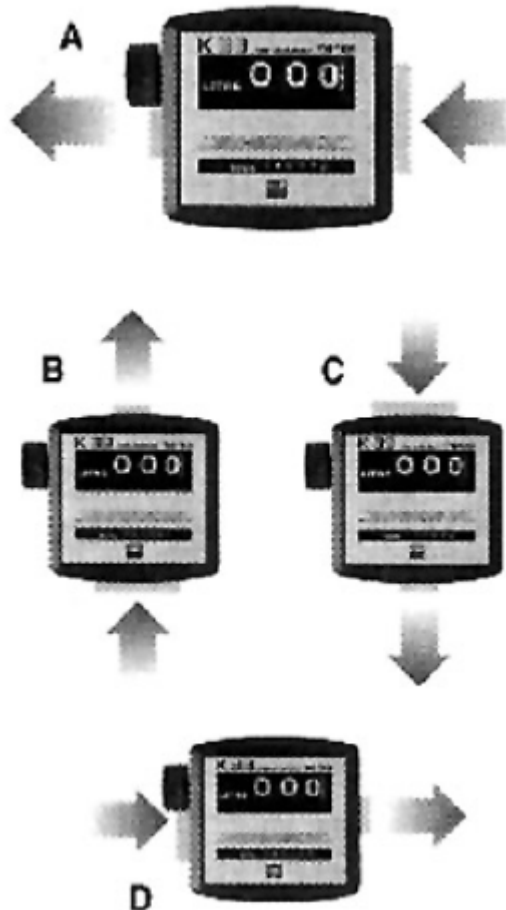

E. Calibration procedure

1. Unscrew the plug (see diagram 1, pos. "14").
2. Purge the system (pump, pipelines, meter) of air by dispensing until the flow stream is full and steady.
3. Stop the flow by shutting off the nozzle, but let the pump running.
4. Reset the batch register by means of the reset knob (pos. "2").
5. Dispense at the flow rate which the best accuracy is required at, by using a calibration container having a capacity not lower than 20 litres. Do not reduce the flow in order to reach the graduated zone of the calibration container. The right method is to start and stop the full flow repeatedly until the required filling is obtained.
6. Compare the indication of the calibration container (real value) with the one of the meter (indicated value).
 - If the indicated value is higher than the real value, loosen the screw (pos. "12");
 - If the indicated value is lower than the real value, tighten the screw (pos. "12").
7. Repeat the operations 4 to 6 until accuracy is satisfactory.
8. Tighten the plug (pos. "14") again. The O ring which the calibration screw is provided with, has the function to avoid accidental loosening of the adjustment screw but does not have any sealing functions. Therefore it is always necessary to properly fix the plug with the sealing gasket (pos. "12").

F. Use

After installation and calibration K44 /K33 is ready to work. Turn the reset knob (see diagram 1, pos. "12") (clockwise if it is mounted on the left of the meter and anticlockwise if it is mounted on the right) until the batch register is completely reset. The totaliser cannot be reset in any way. Make sure that during use pressure does not exceed the value indicated in section "Technical data".

G. Use by Gravity

K33 can also be used in fuel units which are not equipped with pump and where the flow is generated by the difference in fuel level between the tank and the nozzle outlet. As a reference, a system composed of a tank off the ground, with the meter installed right at the bottom of the tank, a 3-m long 1" flexible pipe and a manual nozzle type Self 2000, guarantees a flow rate of approximately 30 litres/minute if the difference in level is higher than 1.5 metres. Longer pipes or nozzles producing higher pressure losses reduce the flow in respect to the existing difference in level. Use by gravity is not recommended with differences in level lower than 1 metre, as the consequent reduced flow rate causes the meter to work outside its guaranteed accuracy range. On field calibration is always advisable in case of gravity installations.

H. Maintenance

No ordinary maintenance is required provided that the meter K33 is properly installed and used. An incorrect filtering on the meter inlet may block or wear out the measuring chamber, thus affecting the meter accuracy. Should this problem occur (see section "Problem, Causes and Solutions") disassemble the measuring chamber, as shown in section "Disassembling/ Reassembling".

ATTENTION

Before disassembling always make sure that all fluid is drained from the meter and pipes connected to it.

Necessary cleaning can be carried out by means of a soft brush or small tool (i.e. a screwdriver). During cleaning be careful not to damage the chamber or the disk. Carefully check the meter and replace the parts which have suffered any possible damage.

Only use the original spare part kits shown in diagram 1 “Exploded view and spare part list”. A new calibration is always necessary after cleaning or replacing the meter parts.

I. Disassembling Reassembling

K33 can be easily disassembled into its main parts without removing the body from the pipes.

J. Meter Unit

To disassemble the meter unit operate as follows:

- a. Remove the reset knob by firmly pulling it axially.
- b. Loosen the 4 retaining screws (see diagram 1, pos. “7”).
- c. Loosen the 2 screws (pos. “5”).

To reassemble the unit reverse the procedure described above.

K. Reset Knob

To modify the reset knob position:

- a. Perform only the operations a) and b) described above.
- b. Take out the plug (see diagram 1, pos. “4”) by pushing it from the inside towards the outside of the cover.
- c. Fix again the plug on the opposite hole by placing it inside the cover and pushing it outwards.
- d. Fix again the meter cover and reset knob.

L. Measuring Chamber

To enter the measuring chamber operate as follows:

- a. Disassemble the meter unit.
- b. Loosen the eight screws (see diagram 1, pos. “7”).
- c. Remove the body cover (pos. “8”) together with the gear unit. During this operation be careful not to damage the gasket (pos. “10”).
- d. Remove the whole measuring chamber (pos. “11”) by lifting it from the meter body and at the same time pulling it back towards the inlet in order to move the O ring (pos. “16”) from its seat at the outlet. To check the inside of the measuring chamber (pos. “15”), remove the O ring and divide the two half chambers containing the nutating disk. Measuring chamber To enter the measuring chamber operate as follows:
 - a. Disassemble the meter unit.
 - b. Loosen the eight screws (see diagram 1, pos. “7”).
 - c. Remove the body cover (pos. “8”) together with the gear unit. During this operation be careful not to damage the gasket (pos. “10”).
 - d. Remove the whole measuring chamber (pos. “11”) by lifting it from the meter body and at the same time pulling it back towards the inlet in order to remove the O ring (pos. “16”) from its seat at the outlet. To check the inside of the measuring chamber (pos. “15”), remove the O ring and divide the two half chambers containing the nutating disk.

M. Gear Unit

To reach the gear unit components:

- a. Remove the cover.
- b. Loosen the screws.
- c. Remove the plate. Now all gears can be reached for inspection. Should the gasket be replaced, remove the bevel gear from the shaft by pulling axially, then remove the gear together with the shaft. The gasket replacement always requires the replacement of the bush provided with the spare part kit. To reassemble reverse the above described procedure paying particular attention to:
 - Lubricate the O ring before installation.
 - Check that the gear unit can rotate freely before fixing the cover.

N. Problems, Causes and Solutions

PROBLEM	POSSIBLE CAUSE	CORRECTIVE ACTION
Leak from the shaft gasket	Damaged gasket	Remove (see section "Gear unit") and replace the O ring and the bush
Insufficient accuracy	Wrong calibration	Repeat calibration following the instructions in section "Measuring chamber"
	Soiled or blocked measuring chamber	Clean the measuring chamber following the instructions in section "Meter unit"
	Air in the fluid	Locate and eliminate leaks in inlet lines
Reduced flowrate	Clogged or blocked measuring chamber	Clean the measuring chamber following the instructions in section "Measuring chamber"
	Blocked or soiled filter	Clean the filter

O. Disposal

The components must be given to companies that specialise in the disposal and recycling of industrial waste and, in particular, the DISPOSAL OF PACKAGING.

The packaging consists of biodegradable cardboard which can be delivered to companies for normal recycling of cellulose.

DISPOSAL OF METAL COMPONENTS

The metal components, both painted and stainless steel, are usually recycled by companies that are specialised in the metal-scraping industry.

DISPOSAL OF ELECTRIC AND ELECTRONIC COMPONENTS:

these have to be disposed by companies that are specialised in the disposal of electronic components, in accordance with the instructions of 2002/96/EC (see text of Directive below).



ENVIRONMENTAL INFORMATION FOR CUSTOMERS IN THE EUROPEAN UNION
European Directive 2002/96/EC requires that the equipment bearing this symbol on the product and/or its packaging must not be disposed of with unsorted municipal waste. The symbol indicates that this product should be disposed of separately from regular household waste streams. It is your responsibility to dispose of this and other electric and electronic equipment via designated collection facilities appointed by the government or local authorities.

DISPOSAL OF OTHER PARTS:

The disposal of other parts such as pipes, rubber seals, plastic components and cables should be entrusted to companies that special in the disposal of industrial waste.

P. Spare Parts

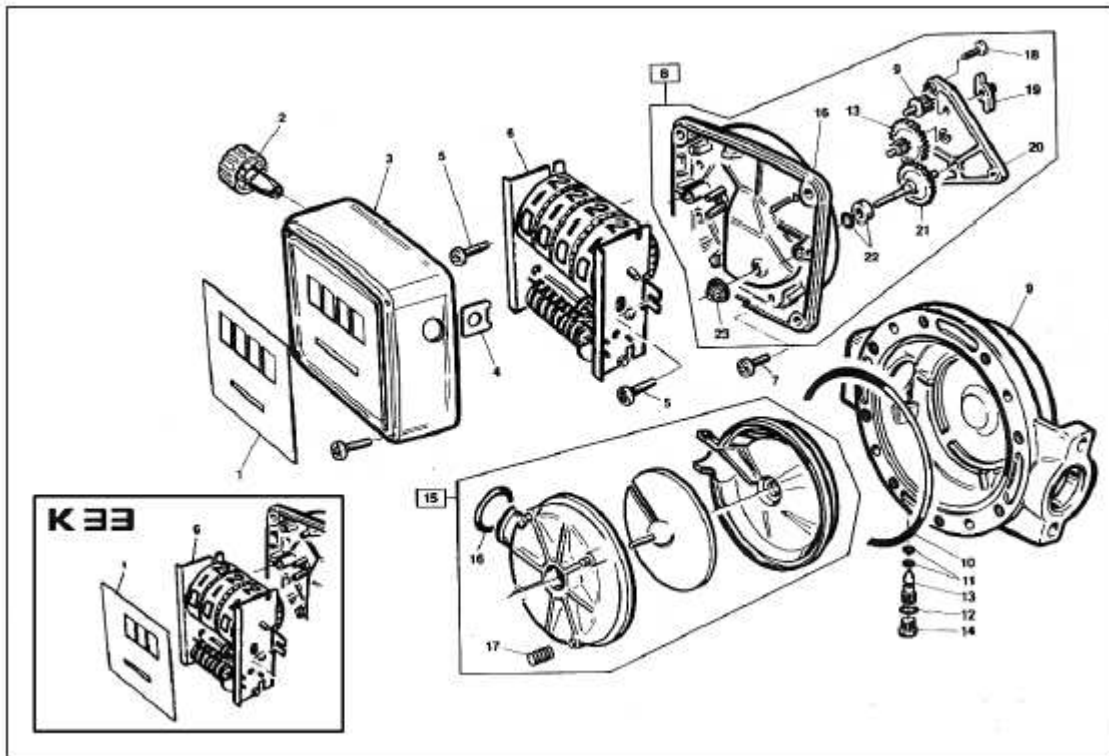

R. Dimensions.

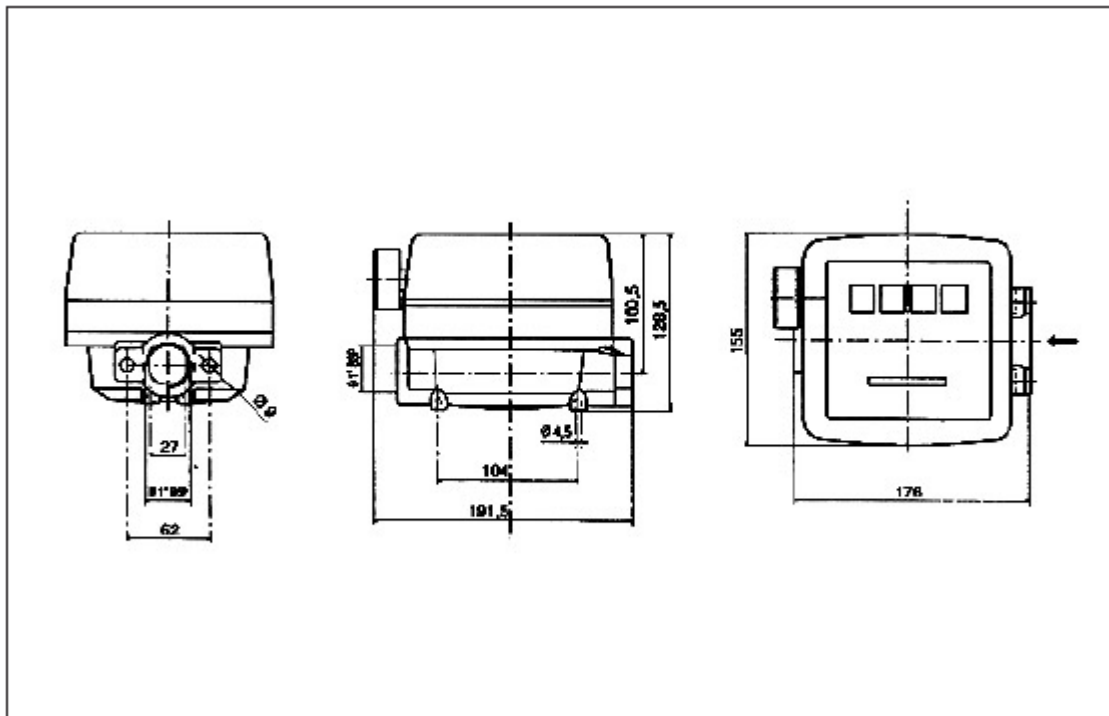

S. Technical Specifications

Meter mechanism	Shield
Flow rate range	20 - 120 l/min
Operating pressure (max)	3,5 bar
Bursting pressure (min)	28 bar
Storage temperature range	-20 ÷ +80 °C
Storage humidity (max)	95%
Operating temperature range	-10 ÷ +60 °C
Loss of pressure (l/min), diesel	30 ÷ 60
Loss of pressure (bar)	0,05 ÷ 2
Accuracy after calibration	+ - 1%
Repeatable (typical)	+ - 0,3%
Accuracy of reading	0,1 l
Connection (inlet/outlet)	1" BSP

VII. Manual Instruction of K600 flow meter



A.Index

- A. Index
- B. General information
- C. Daily use
- D. Calibration
- E. Configuration
- F. Maintenance
- G. Malfunction
- H. Technical specifications

B.General Information

K600 – meter and pulser versions - represents a family of meters developed to satisfy a wide range of requirements for the control, measurement, dispensing and transfer of lubricating oils and fuels. Its measurement principle is based on elliptical gears that provide high accuracy over a wide range of flow rates together with reduced loss of head. The fluid passing through the instrument turns the gears whose rotation transfers constant “fluid units”. The exact measurement of the fluid dispensed is carried out by counting the rotations of the gears and, thus, the “fluid units” transferred. The magnetic coupling, consisting of magnets installed in the gears and a magnetic switch located outside the measuring chamber, guarantees the seal of the measuring chamber and ensures the transmission of the impulses generated by the rotation of the gears to the microprocessor.

The meter housing is manufactured of extruded aluminium and is furnished with external guides for a practical and simple installation. The various models are differentiated by the length of the housing, which is related to their ability to function at higher flow rates.

The meter body is made of die-cast aluminium and fitted with connections for the installation of threaded flanges, suitable for any type of tubing.

At the inlet opening, a filtering disk of stainless steel mesh is installed, which can be accessed from the outside by removing the flange close to the flow inlet side.

METER VERSION

The user can choose between two different operating modes:

Normal Mode: Mode with display of Partial and Total dispensed quantities

Flow Rate Mode: Mode with display of Flow Rate, as well as Partial dispensed quantity

The METER features a non-volatile memory for storing the dispensing data, even in the event of a complete power break for long periods.

Main components: The measurement electronics and the LCD display are fitted in the top part of the meter, isolated from the fluid-bath measuring chamber and sealed from the outside by means of a cover.

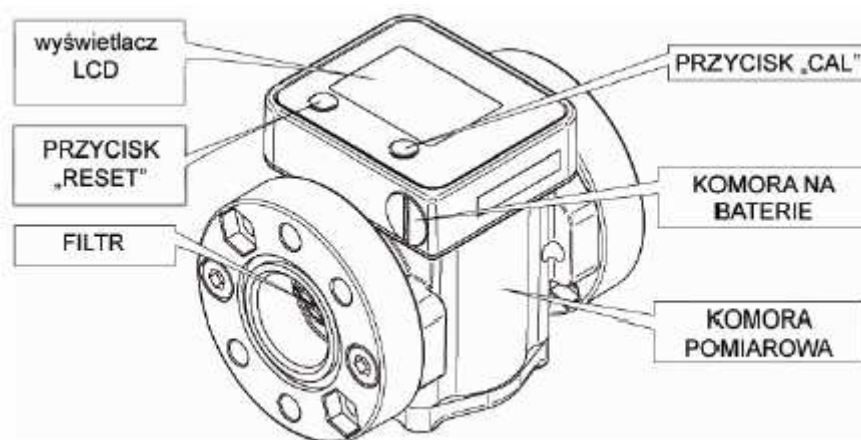

1) LCD display

The “LCD” of the METER features two numerical registers and various indications displayed to the user only when the applicable function so requires.

Key:

1. Partial register (5 figures with moving comma: 0.000 ÷ 99999), indicating volume dispensed from when the RESET button was last pressed;
2. Indication of battery charge;
3. Indication of calibration mode;
4. Totals register (6 figures with moving comma 0.0÷999999 x10 / x100), that can indicate two types of Total:
 - 4.1. General Total that cannot be reset (TOTAL)
 - 4.2. Resettable total (Reset TOTAL)
5. Indication of total multiplication factor (x10 / x100)
6. Indication of type of total, (TOTAL / Reset TOTAL);
7. Indication of unit of measurement of Totals: L=Litres Gal=Gallons
8. Indication of Flow Rate
9. Indication of unit of measurement of Partial:
Qts=Quarts Pts=Pints L=Litres Gal=Gallons

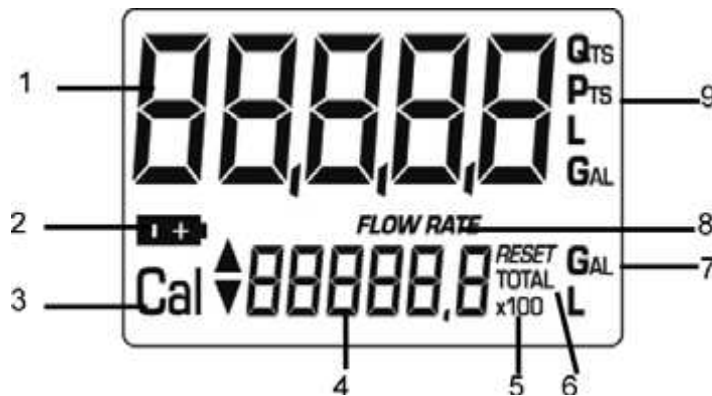

2) User Buttons

The meter features two buttons (RESET and CAL) which individually perform two main functions and, together, other secondary functions.

The main functions performed are:

- for the RESET key, resetting the partial register and Reset Total
- for the CAL key, entering instrument calibration mode

Used together, the two keys permit entering configuration mode where the desired unit of measurement can be set.

3) Battery Housing

The METER is powered by two standard type 1.5 V batteries (size N).

The battery housing is closed by a threaded watertight cap that can be easily removed for quick battery change.

PULSER VERSION

The PULSER version is a pulse emitter (reed bulb) which translates the magnetic field variations generated by gear rotation into electric pulses to be sent to an external receiver. The receiver is to be connected according to the enclosed diagram. The pulser does not need any independent electric power supply, as it is directly powered by the receiver connection.

The issued pulse type is represented by a square wave generated by the voltage variation.

MEASURING CHAMBER

The measuring chamber is located in the lower part of the instrument. It is fitted with connections for the installation of threaded flanges at inlet and outlet. The cover on the bottom part provides access to the measurement mechanism for any cleaning operations.

Inside the measuring chamber are the oval gears which, on turning, generate electrical pulses which are processed by the microprocessor-controlled electronic board.

By applying a suitable calibration factor (meaning a “weight” associated with each pulse), the microprocessor – on-board on meter versions and remote on pulser versions - translates the pulses generated by the fluid volume rotation expressed in the set units of measurement, displayed on the partial and total registers of the LCD.

All K600/2/3 meters are factory set with a calibration factor called FACTORY K FACTOR which is set according to the used fluid (diesel fuel or oil of SAE10 W40 type), for optimal measurement performance. Calibration settings can be changed following the instructions in this manual, but you can return to the factory calibration at any time.

INSTALLATION

K600 METER or PULSER features a 1 inch or 3/4inch inlet and outlet, depending on the fluid for which they were calibrated, threaded and perpendicular. It is designed for fixed in-line installation.

Make sure the threaded connections do not interfere with the inside of the measuring chamber causing the gears to seize.

Do not use any conical connections which may damage the meter body or the connection flange.

Only the Pulser version must be connected by means of 2 cables according to the electrical features.

IMPORTANT: CARRY OUT INSTALLATION BY PLACING THE SUCTION FILTER.

C. Daily Use

PULSER VERSION

The pulser version of K600/3 meter when properly connected to the pulse receiver, does not need any start/stop operation.

METER VERSION

K600 METER is delivered ready for use. No commissioning operations are required even after long storage periods. The only operations that need to be done for daily use are Partial and/or Resettable Total register resetting. Below are the two typical normal operation displays. One display page shows the partial and Reset Total registers. The other shows the partial and general total. Switchover from Reset Total to general total display is automatic and tied to phases and times that are factory set and cannot be changed by the user.



- The Partial register positioned in the top part of the display indicates the quantity dispensed since the RESET key was last pressed.

* The Resettable Total register, positioned in the lower part of the display, indicates the quantity dispensed since the last Resettable Total resetting. The RESET Total cannot be reset until the Partial has been reset, while vice versa, the Partial can always be reset without resetting the RESET Total. The unit of measurement of the two Totals can be the same as the Partial or else different according to the factory or user settings.

The General TOTAL register (Total) can never be reset by the user. It continues to rise for the entire operating life of the meter.

The register of the two totals (Reset Total and Total) share the same area and digits of the display. For this reason, the two totals will never be visible at the same time, but will always be displayed alternately.

The meter is programmed to show one or the other of the two totals at very precise times:

THE GENERAL TOTAL (TOTAL) IS SHOWN DURING METER STANDBY

THE RESET TOTAL IS SHOWN:

- At the end of a Partial reset for a certain time (a few seconds)
- During the entire dispensing stage
- For a few seconds after the end of dispensing. Once this short time has expired.

Meter switches to standby and lower register display switches to General Total

NOTE: 6 digits are available for Totals, plus two icons x 10 / x100. The increment sequence is the following: 100000 x 10 →? 999999 x 10 →? 100000 x 100 →? 999999 x 100

DISPENSING IN NORMAL MODE

This is default dispensing during which, while the count is made, the Partial and Reset Total are displayed at the same time.

Should one of the two keys RESET or CAL be accidentally pressed during counting, this will have no effect. A few seconds after dispensing has ended, on the lower register, the display switches from Resettable Total to General Total: the word RESET above the word TOTAL disappears, and the Reset Total is replaced by the General Total.

This situation is called STANDBY and remains stable until the user operates the meter again.

PARTIAL RESET

The Partial Register can be reset by pressing the RESET key when the meter is in Standby, meaning when the display screen shows the word «TOTAL».

After pressing the RESET key, during reset, the display screen first of all shows all the lit-up digits and then all the digits that are not lit up.

At the end of the process, a display page is first of all shown with the reset Partial and the Reset Total and, after a few moments, the Reset Total is replaced by the NON resettable Total (Total).

RESETTING THE RESET TOTAL

The Reset Total resetting operation can only be performed after resetting the Partial register. The Reset Total can in fact be reset by pressing the RESET key at length while the display screen shows RESET TOTAL as on the following display page:

Schematically, the steps to be taken are:

- 1 Wait for the display to show normal standby display page (with Total only displayed),
2. Press the RESET key quickly
3. The meter starts to reset the Partial.
4. While the display page showing the Reset Total is displayed press the Reset key again for at least 1 second
5. The display screen again shows all the segments of the display followed by all the switched-off segments and finally shows the display page where the reset Reset total is shown.

DISPENSING IN FLOW RATE MODE

It is possible to dispense, displaying at the same time:

- the dispensed partial
- the Flow Rate in [Partial Unit / minute] as shown on the following display page:

Procedure for entering this mode:

- wait for the meter to go to Standby, meaning the display screen shows Total only
- quickly press the CAL key.
- Start dispensing

The flow rate is updated every 0.7 seconds. Consequently, the display could be relatively unstable at lower flow rates. The higher the flow rate, the more stable the displayed value.

WARNING

The flow rate is measured with reference to the unit of measurement of the Partial. For this reason, in case of the unit of measurement of the Partial and Total being different, as in the example shown below, it should be remembered that the indicated flow rate relates to the unit of measurement of the partial. In the example shown, the flow rate is expressed in Qts/min.

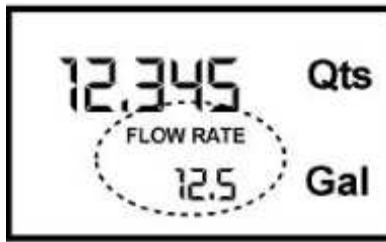

The word “Gal” remaining alongside the flow rate refers to the register of the Totals (Reset or NON Reset) which are again displayed when exiting from the flow rate reading mode. To return to “Normal” mode, press the CAL key again. If one of the two keys RESET or CAL is accidentally pressed during the count, this will have no effect.

WARNING

Even though in this mode they are not displayed, both the Reset Total and the General Total (Total) increase. Their value can be checked after dispensing has terminated, returning to “Normal” mode, by quickly pressing CAL.

PARTIAL RESET

To reset the Partial Register, finish dispensing and wait for the meter to show a Flow Rate of 0.0 as indicated in the illustration then quickly press RESET. Unlike Normal mode, in this case during reset, you do not pass through the stages where the display segments are first lit up and then switched off, but rather the reset partial register is immediately displayed.

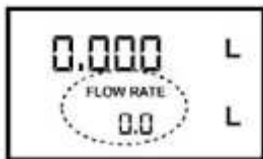

D. Calibration (Only Meter Version)

DEFINITION

Calibration factor or “K Factor” : this is the multiplication factor applied by the system to the electrical pulses received, to transform these into measured fluid units

Factory K Factor: Factory-set default factor. It is equal to 1,000.

This calibration factor ensures utmost precision in the following operating conditions:

- version for oil: Fluid _____ motor oil type SAE10W40
- Temperature _____ 20°C
- Flow rate _____ 6-60 litres/min
- version for diesel fuel: Fluid _____ motor oil type SAE10W40
- Temperature _____ 20°C
- Flow rate _____ 6-60 litres/min

Even after any changes have been made by the user, the factory K factor can be restored by means of a simple procedure.

- User K Factor: Customized calibration factor, meaning modified by calibration.

WHY CALIBRATE

K600 METER is supplied with a factory calibration that ensures precise measuring in most operating conditions.

Nevertheless, when operating close to extreme conditions, such as for instance:

- with fluids close to acceptable range extremes (such as low-viscosity antifreeze or high-viscosity oils for gearboxes)

- in extreme flow rate conditions (close to minimum or maximum acceptable values) on-the-spot calibration may be required to suit the real conditions in which the meter is required to operate.

CALIBRATION PROCEDURE

K600 METER permits making quick and precise electronic calibration by changing the Calibration Factor (K FACTOR).

Two procedures are available for changing the Calibration Factor:

- 1 In-Field Calibration, performed by means of a dispensing operation
- 2 Direct Calibration, performed by directly changing the calibration factor.

The calibration phases can be entered (by keeping the CAL key pressed for a long time) to :

- Display the currently used calibration factor
- Return to factory calibration (Factory K Factor) after a previous calibration by the user
- Change the calibration factor using one of the two previously indicated procedures.

1 In calibration mode, the partial and total dispensed quantities indicated on the display screen take on different meanings according to the calibration procedure phase.

2 In calibration mode, the METER cannot be used for normal dispensing operations.

3 In "Calibration" mode, the totals are not increased.

ATTENTION

The METER features a non-volatile memory that keeps the data concerning calibration and total dispensed quantity stored for an indefinite time, even in the case of a long power break; after changing the batteries, calibration need not be repeated.

DISPLAY OF CURRENT CALIBRATION FACTOR AND RESTORING FACTORY FACTOR

By pressing the CAL key while the appliance is in Standby, the display page appears showing the current calibration factor used.



Two cases can occur:

a) If no calibration has ever been performed, or the factory setting has been restored after previous calibrations, the following display page will appear:

The word "Fact" abbreviation for "factory" shows that the factory calibration factor is being used

B) If, on the other hand, calibrations have been made by the user, the display page will appear showing the currently used calibration factor (in our example 0,998).

The word "user" indicates a calibration factor set by the user is being used.

The flow chart alongside shows the switchover logic from one display page to another

In this condition, the Reset key permits switching from User factor to Factory factor. To confirm the choice of calibration factor, quickly press CAL while "User" or "Fact" are displayed.

After the restart cycle, the meter uses the calibration factor that has just been confirmed

WARNING

When the Factory Factor is confirmed, the old User factor is deleted from the memory

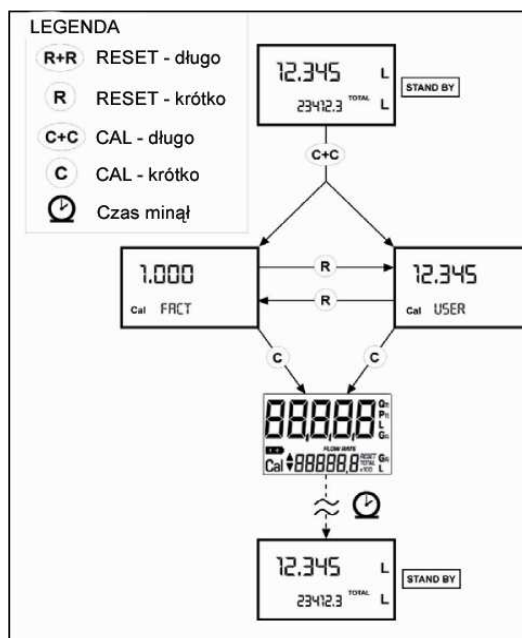

IN-FIELD CALIBRATION





This procedure calls for the fluid to be dispensed into a graduated sample container in real operating conditions (flow rate, viscosity, etc.) requiring maximum precision.





ATTENTION

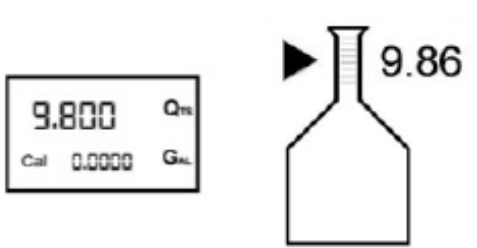

For correct METER calibration, it is most important to:

- completely eliminate air from the system before calibrating;
- use a precise Sample Container with a capacity of not less than 5 litres, featuring an accurate graduated indicator.
- ensure calibration dispensing is done at a constant flow rate equivalent to that of normal use, until the container is full;
- not reduce the flow rate to reach the graduated area of the container during the final dispensing stage (the correct method during the final stages of sample container filling consists in making short top-ups at normal operation flow rate)
- after dispensing, wait a few minutes to make sure any air bubbles are eliminated from the sample container; only read the Real value at the end of this stage, during which the level in the container could drop.
- Carefully follow the procedure indicated below.

IN-FIELD CALIBRATION PROCEDURE

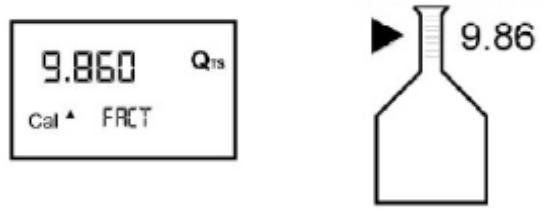
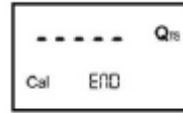
Nr	OPERATION	DISPLAY
1	NONE METER in normal mode, not in counting mode.	
2	LONG CAL KEY KEYING The meter enters calibration mode, <<CAL>> and displays the calibration factor in use instead of partial. The words "Fact" and "USER" indicate which of the two factors (factory or user) is currently in use. important:	
3	LONG RESET KEY KEYIG The meter show "CAL" and the zero partial total. The meter is ready to perform in-field calibration	
4	DISPENSING INTO SAMPLE CONTAINER Without pressing any button start dispensing into the sample container. 	

	<p>Dispensing can be interrupted and started again at will. Continue dispensing until the level of the fluid in the sample container has reached the graduated area. There is no need to reach a preset quantity.</p> <p>Indicated value Real value</p> 	
5	<p>SHORT RESET KEY KEYING</p> <p>The meter informed that the calibration dispensing operation is finished. Make sure dispensing is correctly finished before performing this operation. To calibrate the meter, the value indicated by the partial totaliser (example 9.800) must be forced to the real value marked on the graduated sample container. In the bottom left part of the display an arrow appears (upwards and downwards), that shows the direction (increase or decrease) of the USER K FACTOR value change when the operations 6 or 7 are performed.</p>	
6	<p>SHORT RESET KEY KEYING</p> <p>Changes the direction of the arrow. The operation can be repeated as many times as you wish</p>	
7	<p>SHORT/LONG CAL KEY KEYING</p> <p>The indicated value changes in the direction indicated the arrow: - one unit for every short CAL key keying - continually if the CAL key is kept pressed. (for the first 5 units slowly and then quickly). If the desired value is exceeded, repeat the operations from point 6..</p>	
8	<p>LONG RESET KEY KEYING</p> <p>The meter is informed that the calibration procedure is finished. Before performing this operation, make sure the INDICATED value is the same as the REAL value</p> <p>Indicated value Real value</p> 	

	The meter calculates the new USER K FACTOR; this calculation could require a few seconds, depending on the correction to be made. During this operation the arrow disappears but the CAL indication remains. If this operation is performed after operation (5), without changing the indicated value, the USER K FACTOR would be the same as the FACTORY K FACTOR, thus it is ignored.	
9	NO OPERATION At the end of the calculation, the new USER FACTOR is shown for a few seconds, after which the restart cycle is repeated to finally achieve standby condition. IMPORANT: From now on, the indicated factor will become the calibration factor used by the meter and will continue to remain such even after the battery change	
10	NO OPERATION Meter stores the new calibration factor and is ready for dispensing, applying the newly defined USER K FACTOR.	

DIRECT MODIFICATION OF K FACTOR







This procedure is especially useful to correct a "mean error" obtainable on the basis of several performed dispensing operations. If normal METER operation shows a mean percentage error, this can be corrected by applying to the currently used calibration factor a correction of the same percentage. In this case, the percentage correction of the USER K FACTOR must be calculated by the operator in the following way:



$$\text{New cal. Factor} = \text{Old cal Factor} \times \left(\frac{100 - E\%}{100} \right)$$

Example:

Error percentage found E%	- 0.9 %
CURRENT calibration factor	1,000
New USER K FACTOR	1,000 * [(100 - (- 0,9))/100]=
	1,000 * [(100 + 0,9)/100] = 1.009

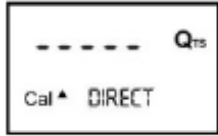
If the meter indicates less than the real dispensed value (negative error) the new calibration factor must be higher than the old one as shown in the example. The opposite applies if the meter shows more than the real dispensed value (positive error).

Nr	OPERATION	DISPLAY CONFIGURATION
1	<p>NONE Meter is normal mode, not in counting mode</p>	
2	<p>LONG CAL KEY KEYING Meter enters calibration mode, shows "CAL" and displays the calibration factor being used instead of the partial. The words "Fact" and "USER" indicate which of the two factors (factory or user) is currently being used.</p>	
3	<p>LONG RESET KEY KEYING The meter shows "CAL" and the zero partial total. Meter is ready to perform in-field calibration by dispensing - see previous paragraph</p>	
4	<p>LONG RESET KEY KEYING We now go on to Direct change of the calibration factor: the word "Direct" appears together with the Currently Used calibration factor. In the bottom left part of the display, an arrow appears (upwards or downwards) defining the direction (increase or decrease) of change of the displayed value when subsequent operations 5 or 6 are performed.</p>	
5	<p>SHORT RESET KEY KEYING Changes the direction of the arrow. The operation can be repeated to alternate the direction of the arrow.</p>	
6	<p>SHORT/LONG CAL KEY KEYING The indicated value changes in the direction indicated by the arrow - one unit for every short CAL key keying - continually if the CAL key is kept pressed. The speed increase rises by keeping the key pressed. If the desired value is exceeded, repeat the operation from point (5)</p>	
7	<p>LONG RESET KEY KEYING The meter is informed that the calibration procedure is finished. Before performing this operation, make sure the indicated value is that required.</p>	

8	<p>NO OPERATION</p> <p>At the end of the calculation, the new USER K FACTOR is shown for a few seconds, after which the restart cycle is repeated to finally achieve standby condition.</p> <p>IMPORTANT: From now on, the indicated factor will become the calibration factor used by the meter and will continue to remain such even after a battery change</p>	
9	<p>NO OPERATION</p> <p>Meter stores the new calibration factor and is ready for dispensing, applying the newly defined USER K FACTOR..</p>	

E. Meter configuration

METER is fitted with a menu by which the user can select the main unit of measurement, Quarts (Qts), Pints (Pts), Litres (Lit), Gallons (Gal); The combination between the unit of measurement of the Partial Register and that of the Totals is set according to the following table:

Combination no.	Unit of Measurement	
	Partial Register	Total Register
1	Liters (Lit)	Liters (Lit)
2	Gallons (Gal)	Gallons (Gal)
3	Quarts (Qts)	Gallons (Gal)
4	Pints (Pts)	Gallons (Gal)

To choose between the 4 available combinations:

- Wait for the METER to go to Standby
- then press the CAL and RESET keys together. Keep these pressed until the word "UNIT" appears on the screen together with the unit of measurement set at that time (in this example Litres / Litres):



Every short press of the RESET key, the various combinations of the units of measurements are scrolled as shown below:

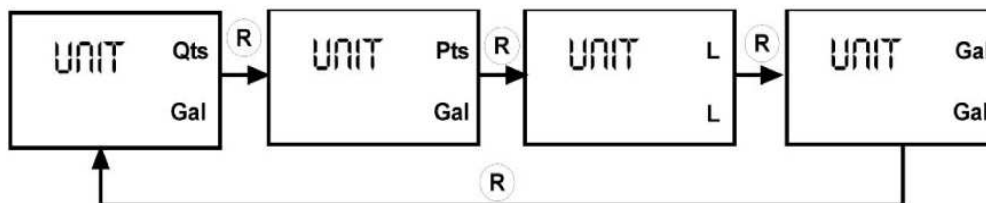
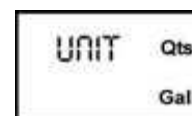

By pressing the CAL key at length, the new settings will be stored, the METER will pass through the start cycle and will then be ready to dispense in the set units.

ATTENTION

The Resettable Total and Total registers will be automatically changed to the new unit of measurement.

NO new calibration is required after changing the Unit of Measurement.

F. Maintenance

The METER has been designed to require a minimum amount of maintenance.

The only maintenance jobs required are:

- Battery change – necessary when batteries have run down (ONLY FOR METER VERSIONS)
- Cleaning the measuring chamber. This may be necessary due to the particular nature of the dispensed fluids or due to the presence of solid particles following bad filtering.

1 Changing the batteries

The METER is complete with 2 x 1.5 V. alkaline batteries SIZE N.

The METER features two low-battery alarm levels:

1) When the battery charge falls below the first level on the LCD, the fixed battery symbol appears.

In this condition, the METER continues to operate correctly, but the fixed icon warns the user that it is time to change the batteries.

2) If meter operation continues without changing the batteries, the second battery alarm level will be reached which will prevent operation. In this condition the battery icon starts to flash and is the only one to remain visible on the LCD.

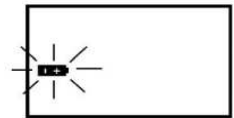

ATTENTION

Do not discard the old batteries into the environment. Refer to local disposal regulations.

To change the batteries, with reference to the spare parts list positions, proceed as follows:

- Press RESET to update all the totals
- Unscrew the battery cap (pos.8)
- Remove the old batteries
- Place the new batteries in the same position as the old ones, making sure the positive pole is positioned as indicated on the cover (pos.9) Re-tighten the battery cap, making sure the seal (pos.1) are correctly positioned.
- The METER will switch on automatically and normal operation can be resumed.

The METER will display the same Reset Total, the same Total and the same Partial indicated before the batteries were changed.

After changing the batteries and, subsequently, every time there is a power break, the METER will start again and use the same calibration factor used when the break occurred. The meter does not therefore need calibrating again.

2. Cleaning the MEASURING CHAMBER

The K600 measuring chamber can be cleaned without removing the instrument from the line on which it is fitted. Make sure the gears are turning freely before closing the cover.

ATTENTION

Always make sure that the liquid has drained from the meter before cleaning.

To clean the chamber, proceed as follows (with reference to the exploded diagram positions):

- Loosen the four retention screws of the lower cover (pos. 7).
- Remove the cover (pos. 7) and the seal (pos. 6).
- Remove the oval gears.

- Clean where necessary. For this operation, use a brush or pointed object such as a small screwdriver.

Be careful not to damage the body or the gears.

- To reassemble the instrument, perform the operations in the opposite sequence.

ATTENTION

Perform the assembly diagram to reassemble the gears.



K600/3

ATTENTION

Only one of the two gears, modularly coupled as shown in the picture aside, features magnets. Observe the position of the gear with magnets, as shown in the figure. Fit the second gear (without magnets) with axis greater than 90° compared to the first gear.

3. Cleaning the filter

The filter cleaning interval is to be defined depending on the impurities contained in the fluid. To perform this operation, remove the device from the line on which it is installed, as the filter is placed between the meter body and tube connection flange.

ATTENTION

Always make sure that the liquid has drained from the meter before cleaning.

To clean the filter, proceed as follows (with reference to the exploded diagram positions):

- To access the filtering disk of the K600/3, loosen the 2 fixing screws of the connection flange at the inlet. Remove both flanges if it is necessary for the system.
- Remove the meter from the line, being careful to remove also the gaskets between the flanges and threaded connections of K600.
- Slide out the filter (pos. 9)
- Clean the filter with compressed air.
- Carry out the reverse procedure to reassemble the filter.

G.Malfunctions

ELECTRONIC MALFUNCTIONS

Problem	Possible Cause	Remedial Action
LCD: no indications	Bad battery contact	Check battery contacts
Not enough measurement precision	Wrong K FACTOR	With reference to paragraph H, check the K FACTOR
	The meter works below minimum acceptable flow rate	Increase the flow rate until an acceptable flow rate range has been achieved
The meter does not count, but the flow rate is correct	possible electronic board problems	Contact your dealer

MECHANICAL MALFUNCTIONS

Problem	Possible Cause	Remedial Action
Reduced or zero flow rate	Gears blocked	Clean the measuring chamber
The meter does not count, but the flow rate is correct	Incorrect installation of gears after cleaning	Repeat the reassembly procedure
Inaccuracy	Incorrect calibration of pulser version	Calibrate the device with the pulse receiver

	Working flow rate outside the flow rate range	Reduce or increase the flow rate to return to the indicated flow rate range
High loss of head	Dirty filter	Clean the filter
	Braked gears	Clean the measuring chamber
It does not count	Wrong gear installation	Check the position of the gear with magnet
	Faulty bulb	Change the bulb

H. Technical Specifications

		K600/3 (oil)		K600/3 (diesel fuel)	
		Meter	Pulser	Meter	Pulser
Resolution	L/pulse	35	35	33,5	33,5
	Gal/pulse	132,5	132,5	127	127
Flow rate range	L/min	6÷60		10÷100	
Operating pressure	bar	70		30	
Bursting pressure	bar	140		60	
Measurement system		Elliptical gears			
Storage temperature	°C	-20 ÷ +70			
Storage humidity	H.R.	95%			
Operating temperature (max)	°C	-10 ÷ +60			
Loss of Head at maximum flow rate	bars	0,3 (SAE 10W/40@20°C)		0,3 (diesel fuel @20°C)	
Compatible fluids		oil		diesel fuel	
Viscosity Range	cSt	10 ÷ 2000		2 ÷ 5,35	
Accuracy (within capacity range)		+- 0,5			
Repeatability		0,20%			
Weight	kg	1,6		1,6	
Input and output connection thread		3/4" Gaz		1" Gaz	
Batteries		2x1,5 Volt		2x1,5 Volt	
Batterie Life (expected)		18-36 months		18-36 months	

I.Spare Parts

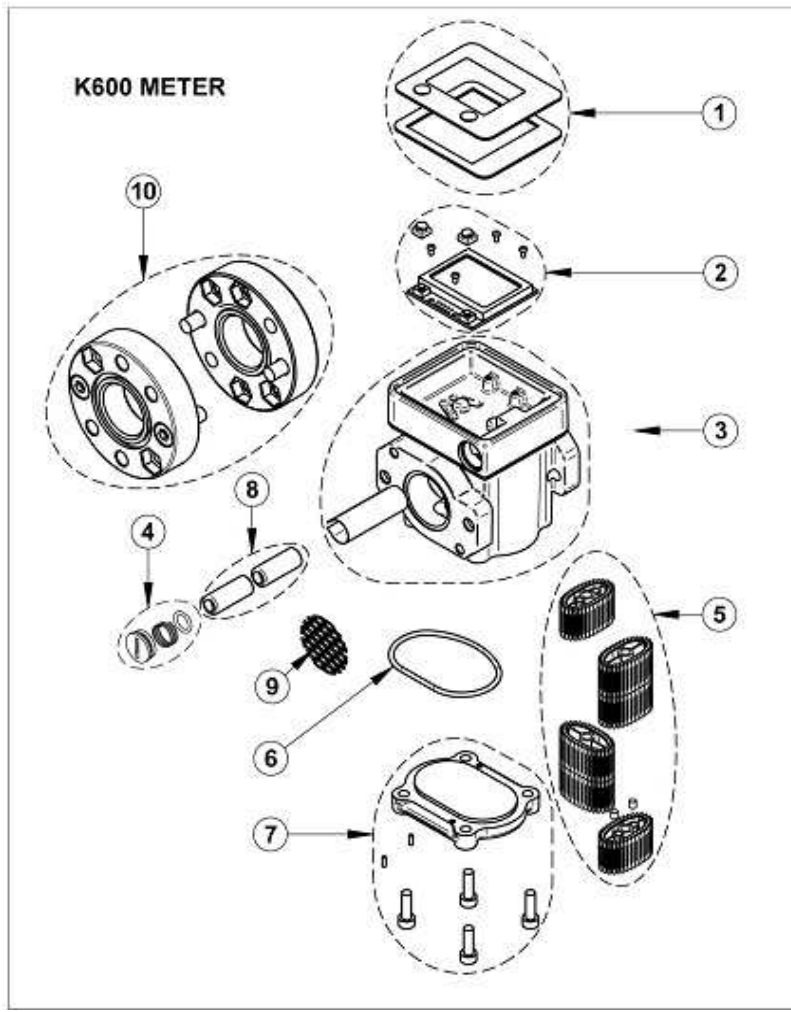

VIII. Overfill Prevention Device

A. Mechanical protection

The mechanical protection consists of Fillstop device placed on the outlet of filling line. When oil level in the device reaches about a half of plunger height, the admission closes almost entirely.

System works only in case of pressure fuel-filling.

Required fuel-filling parameters :

Minimal pressure : 10 mbar (0,15PSI) Maximal pressure : 7 bar (100 PSI)

Minimal flow-rate 50 liters/min. Maximal flow-rate : 580 liters/min

Operating :

1. Connect the filling line with valve.
2. Start fuel-filling.
3. When the tank is full, Fillstop valve cuts fuel inlet. The action prevents overfilling. If the tank is filled to the level when the Fillstop valve closes, switch off the pump. In case of pressure descent in the filling line, Fillstop valve lets the fuel down from the filling line.
4. Take out of service the filling line.

Attention : This valve functions well only with pure fuel. Any contamination or a foreign matter in fuel can cause irregularity in valve operating and can invalidate the warranty.



B. Electronic protection

The electronic protection consists of a probe situated in the upper part of the inner tank and of a clamp located in the distribution box.

Operating bases on the electric resistance of thermistor PTC, situated in the probe. When the value of resistance of the thermistor changes, the value of power. During fuel-filling, indicator is connected by cable and plug with a device controlling the overfill protection in tank. The indicator is energized and it warms up the thermistor. Temperature conditions the power value and in effect causes the opening of the valve which cuts tanks.

In the moment, when fluid reaches the filling level, thermistor dives in fuel and is cooled/ quenched. In effect the electric resistance of sensor changes immediately. The change of resistance provokes change of power in the circuit of indicator. In effect, the device controlling overfill protection of tank stops immediately the process of fuel-filling by closing the gate valve.

The probe works at the level determined by the position of the upper wall of tank. Approximately, it is 95% of maximal volume.



IX. Level and Leak Detector

A. Index

- B. Index
- C. Apollo Ultrasonic Oil Level Monitor – General information
- D. Tools required
- E. Installation instructions

B. Apollo Ultrasonic Oil Level Monitor – General Information

- The Apollo Ultrasonic Oil Level Monitor measures the level of Sable oil In your tank In 10 graduations of the tank height.
- We give a full 1 year warranty subject to normal conditions. Supplied with long life lithium battery. The warranty becomes invalid if the sealed unit is opened.
- Suitable for use in tanks for the storage of diesel fuel, kerosene, gas oil types A2, C1, C2, and D as defined by BS 2869. Check with the manufacturer and/or supplier before using with any other fluids.
- The Apollo Ultrasonic will fit easily to most standard oil storage tanks (plastic or steel) that has a 20 mm, 32 mm or 38 mm (1 ½”) gauge hole.

C. Tools Required

Star/Philips head screwdriver.

D. Installation Instructions

1. **Setting Receiver**

- Accurately measure the height of your tank. Using the tank height **chart 1**, read across to the relevant multi switch settings. The multi switches are located in a recess at the back of the receiver above the pins.
- Using screwdriver or tip of ball point pen, flip the relevant switch(es) upwards (=ON). As an example, if the tank is 850 mm height, set switches **ON (Up)** number **4 & 8**.

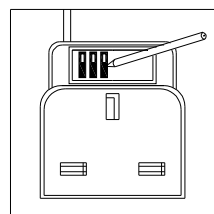

Your Apollo Ultrasonic receivers now programmed to your tank height.

2. **Matching Receiver and Transmitter**

You should match the receiver with the transmitter so that the system code is unique to your tank. You only need to do this once.

- Plug receiver into a suitable and convenient electrical socket and switch on. The display screen on the front of the receiver will show a flashing top bar as shown in diagram. This indicates that the receiver is awaiting a unique code. The flashing top bar will last for 2 minutes **during which time you can match the transmitter to the receiver.**

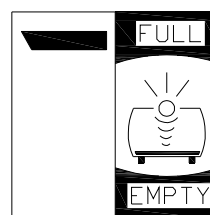

- Hold the transmitter against the receiver right hand side, as shown, so that the black dots are touching each other (important!) for about 20 seconds to allow unique code to be transferred. Bars will increase up the display screen. When all 10 bars are shown they will flash to indicate that the unique code is transferred.

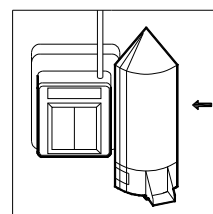

3. **Fitting Transmitter**

The procedure is the same for fitting to both old and New tanks.

For tanks with pre-drilled 20 mm Or 32 mm hole:

- Remove cap from hole and insert transmitter, ensuring the Feather seal is securely in place.
- Ensure the transmitter is **vertical** on top of the tank.
- Tighten on to the tank using the 2 stainless steel self-tapping screws supplied. **Do not overtighten.**

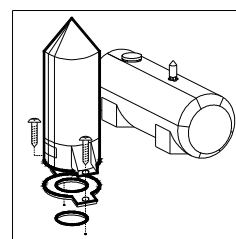

For tanks with 1 ½” (38mm) BSP gauge socket:

- Unscrew cap from hole and fit the adapter provided by screwing into gauge socket.
- Fit the transmitter to the adaptor on the tank as described above.
The Apollo Ultrasonic Oil Level Monitor is now fully installed and signals should be received every hour. After initial installation it may take one hour for the correct oil level indication to be displayed on screen.

NOTE:

In the event of a power failure or if the receiver is switched off or moved to a new socket: When power returns again or unit is switched on, the receiver display screen will show the top bar flashing. **There is no need to repeat the matching instruction.** The top bar will continue to flash for 2 minutes, after which time the display screen will be blank, whilst the unique signal is located. This may take up to one hour.

4. Apollo Ultrasonic on Screen Displays

NORMAL MESSAGES

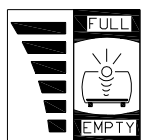

FULL

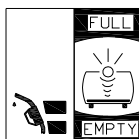

EARLY WARNING

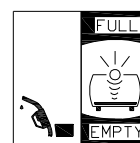

ALMOST EMPTY

OTHER MESSAGES

Blank screen after installation or following a power failure.

Receiver Whiting for Signac.

- Do Nothing! Signal should be received within one hour.

Flashing triangle, no bars.

No radio signal (after waiting for 2 hours)

- Check for correct matching procedure
- Location of receiver to transmitter (try repositioning receiver)
- Moisture ingress due to seal damage
- Exhausted battery

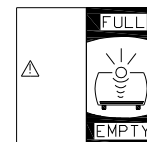

No signal

Flashing triangle, Middle bar only.

No ultrasonic echo (Could be condensation on sensing cone).

- Do nothing and allow to dry naturally

If message persists

- Check the transmitter sensor cone is clean
- Check that the transmitter is vertical
- Check that the transmitter seal is undamaged

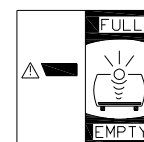

No echo

All bars and LED (double) flashing

Bund Alarm (Could be a leak in the inner skin of the tank)

- Determine if fuel is escaping from the inner skin of the tank, if it is, then replace the tank
- If there is no leak, check that the bund is suspended a minimum of 100 mm above the base of the bund

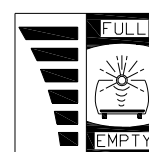

Bund Alarm

APOLLO ULTRASONIC RECEIVER MULTI SWITCH SETTING CHART (1)

Measure the vertical height of the tank from the transmitter position on top of the tank to the bottom of the tank. Read to the nearest measurement on the chart.

Height of tank [mm]	Set switches ON	Height of tank [mm]	Set switches ON
500	Wszystkie wyłączone	1750	3,4,5,6,7
550	7	1800	2,8
600	6,8	1850	2,7,8
650	6,7,8	1900	2,6,7
700	5,7	1950	2,5
750	5,6	2000	2,5,7,8
800	5,6,7,8	2050	2,5,6,8
850	4,8	2100	2,4
900	4,6	2150	2,4,7
950	4,6,7	2200	2,4,6,8
1000	4,5,8	2250	2,4,6,7,8
1050	4,5,7,8	2300	2,4,5,7
1100	4,5,6,7	2350	2,4,5,6
1150	3	2400	2,4,5,6,7,8
1200	3,7,8	2450	2,3,8
1250	3,6,8	2500	2,3,6
1300	3,5	2550	2,3,6,7
1350	3,5,7	2600	2,3,5,8
1400	3,5,6,8	2650	2,3,5,7,8
1450	3,5,6,7,8	2700	2,3,5,6,7
1500	3,4,7	2750	2,3,4
1550	3,4,6	2800	2,3,4,7,8
1600	3,4,6,7,8	2850	2,3,4,6,8
1650	3,4,5,8	2900	2,3,4,5
1700	3,4,5,6	3000	2,3,4,5,6,8